

OpenLCB Standard	
OpenLCB-CAN Physical Layer	
09/17/10	Adopted

1 Introduction (Informative)

This document defines the physical layer for carrying OpenLCB-CAN over a single Controller Area Network (CAN) bus. It is not otherwise normative.

2 Intended Use (Informative)

- 5 Conforming OpenLCB-CAN nodes can be connected by cables to form a linear CAN bus with optional short stubs. OpenLCB-CAN nodes generally have two RJ45 modular connectors and can be daisy-chained together with suitable computer-network (“Ethernet”) cables. A CAN terminator is installed by the user at each end of the main bus.

Users can expect to be able to form networks within limitations:

- 10
- Total cable length of 1000 ft / 300m; stub cables count double their length in that total; nodes count as 20 ft / 6m in that total
 - Never less than 1 ft / 30cm of cable between nodes, nor between a stub connection and a node.
 - No more than 50 nodes connected
- 15 A limited amount of power can be distributed via the cable, allowing a few nodes to draw power from a short (20 ft / 6m) length of the common bus.

3 References and Context (Normative)

In this document

- 20
- “RJ45” refers to the miniature 8 position unkeyed plug and jack defined in sections Section 6.1.1.3 and Section 6.1.1.4, respectively, of the TIA-968-A specification.
 - “UTP” refers to CAT-3 or better cable as defined in TIA/EIA-568-B or the successor TIA/EIA- 568-C.
 - “CAN” refers to the electrical and protocol specifications as defined in ISO 11898-1:2003 and ISO 11898-2:2003 and their successors.
- 25 External certification of parts shall be accepted for conformance to these standards. Conformance with a later version of a standard shall be accepted as conformance with the referenced versions.

4 Physical Interconnection (Normative)

30 CAN connections between nodes shall be made using UTP cable. There shall be a RJ45 plug on the cable and RJ45 jack on the node unless the cable is permanently attached to the node.

The signal, conductor and pair assignments shall be:

Conductor	Signal Name	TIA/EIA-568-A (Informative)	TIA/EIA-568-B (Informative)
1	CAN_H	white/green	white/orange
2	CAN_L	green	orange
3	CAN_GND	white/orange	white/green
4	reserved	blue	blue
5	reserved	white/blue	white/blue
6	CAN_SHIELD	orange	green
7	PWR_NEG	white/brown	white/brown
8	PWR_POS	brown	brown

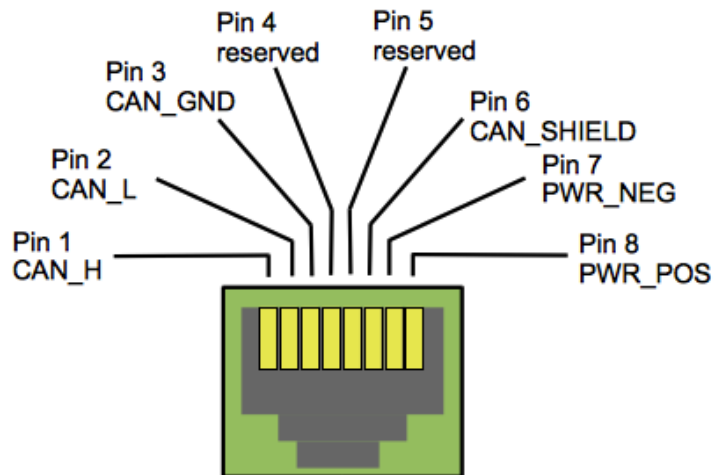

Figure 1: Jack viewed from plug side

35 Cables, including cables attached to nodes, shall carry conductors 1 & 2 as a pair, and conductors 3 & 6 as a pair.

Cables may, but are not required to, carry conductors 4 and 5. Conductors 4 and 5, if present, shall be carried as a pair.

Cables may, but are not required to, carry conductors 7 and 8. Conductors 7 and 8, if present, shall be carried as a pair.

- 40 If a node provides two or more connections, conductors 1 through 8 shall be provided on all connections. Conductors 1 through 7 shall be connected in parallel on all connections. If the node does not provide power on pin 8 on all connectors, pin 8 on all connectors shall be connected in parallel. All wiring discussed in this paragraph shall be rated to carry at least 1A.

Nodes shall connect conductors 3 and 6 . This connection shall be rated to carry at least 1A.

- 45 A node may, but is not required to, connect conductor 7 with conductors 3 and 6. Nodes that require conductor 7 to be connected to conductors 3 and 6 for proper operation shall connect conductor 7 to conductors 3 and 6.

Voltages of up to 100 volts AC or either polarity DC on the reserved conductors 4 and 5 shall not damage the node nor prevent normal operation of the node.

- 50 Voltages of up to 27 volts AC or either polarity DC on the PWR_NEG / PWR_POS conductors shall not permanently damage the node.

5 Data Transport (Normative)

Data shall be transferred using a CAN signal at 125kbps and CAN frame protocol.

- 55 The bit slew rate of the CAN signal, as transmitted, shall be less than 10V/microsecond and more than 3.5V/microsecond.

Any devices providing bus termination shall conform to CAN requirements for that termination.

A node may, but is not required to, provide a method for bus termination as part of the node. If so, there shall be a user-accessible method for enabling and disabling the termination, and the node shall be shipped from the original manufacturer with the termination disabled.

60 6 Supply of Power (Normative)

A node may, but is not required to, provide power to the cable PWR_POS / PWR_NEG conductors.

If a node provides power, it shall provide at least 9VDC and no more than 15VDC from zero current draw up to its specified maximum current. Its specified maximum current shall not exceed 500 mA.

- 65 The specified maximum current shall be permanently written on the node in a location visible to the user. This label is required whether or not the node provides power to the cable.

7 Consumption of Power (Normative)

Nodes may, but are not required to, draw power from the PWR_POS / PWR_NEG conductors in the cable. Nodes shall not draw more than 500 mA at any PWR_POS / PWR_NEG voltage from 7.5VDC to 15VDC. Nodes that draw power shall operate properly with a supply voltage of 7.5VDC to 15VDC

- 70 on the PWR_POS / PWR_NEG conductors. The maximum current drawn by each node shall be permanently written on that node in a location visible to the user. This label is required whether or not the node draws power from the cable.

Table of Contents

1 Introduction (Informative).....	1
2 Intended Use (Informative).....	1
3 References and Context (Normative).....	1
4 Physical Interconnection (Normative).....	2
5 Data Transport (Normative)	3
6 Supply of Power (Normative)	3
7 Consumption of Power (Normative)	3

75